

High cost performance connecting rod clamp with compact structure, large capacity and strong durability

Model Representation

HCLT^① - ^② (Example: HCLT06-R)

① Dimensions (refer to specification sheet)

② Clamping arm installation direction

HCLT	02	-	L: left F: forward R: right	L: left F: forward R: right
	04 06 10 16 25			

Specification

Model		HCLT02	HCLT04	HCLT06	HCLT10	HCLT16	HCLT25	
Cylinder capacity (when oil pressure is 7MPa)		(kN)	3.2	4.5	6.1	9.8	15.7	25.4
Clamping force※1	When the oil pressure is 7MPa	(kN)	2.4	3.2	4.0	6.8	11.1	17.1
	Clamping arm length	(mm)	36.5	42	50	56.5	69.5	87.5
Bore of cylinder		(mm)	25	30	35	44	56	70
Diameter of main rod		(mm)	12	14	14	16	22.4	28
Cylinder area (clamping)		(cm ²)	4.9	7.1	9.6	15.2	24.6	38.5
Full stroke		(mm)	20.5	23.5	26	29.5	36	45
Clamp stroke		(mm)	17.5	20.5	23	26.5	33	42
Stroke margin		(mm)	3	3	3	3	3	3
Maximum flow		(L/min)	1.0	1.6	2.6	4.7	9.5	18.9
Cylinder capacity		(cm ³)	10.0	16.7	25.0	44.8	88.6	173.3
Return spring force	Clamping position (Fs)	(kN)	0.25	0.40	0.63	0.81	1.52	1.58
	Release position	(kN)	0.13	0.19	0.33	0.44	0.81	0.83
Recommended piping inner diameter ※2		(mm)	φ 6	φ 6	φ 6	φ8	φ8	φ10
Maximum allowable mass of clamping arm ※3		(kg)	0.2	0.3	0.5	1.0	1.5	3.0
Mass		(kg)	0.7	1.0	1.5	2.4	4.3	8.1

Operating oil pressure range: 2.5 to 7MPa Guaranteed pressure resistance: 10.5MPa Operating ambient temperature: 0-70°C

Operating fluid: ordinary mineral oil-based hydraulic oil (equivalent to ISO-VG32)

※ 1: It indicates the clamping force when installing the standard clamping arm.

The clamping force varies with the length of the clamping arm.

※ 2: When multiple clamps are used and the oil pressure piping is long, please pay attention to the piping inner diameter.

※ 3: It indicates that the shape is the same as that of the standard clamping arm, and that only the clamping arm mass is increased when the length is increased.

Overall Dimension

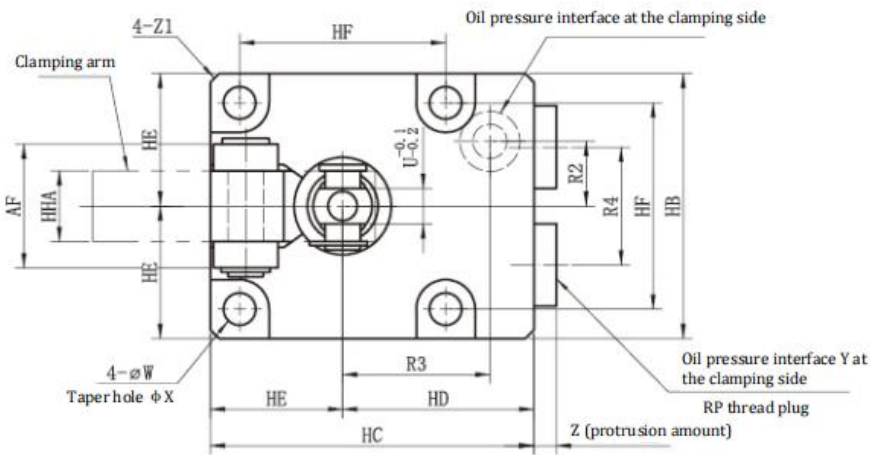
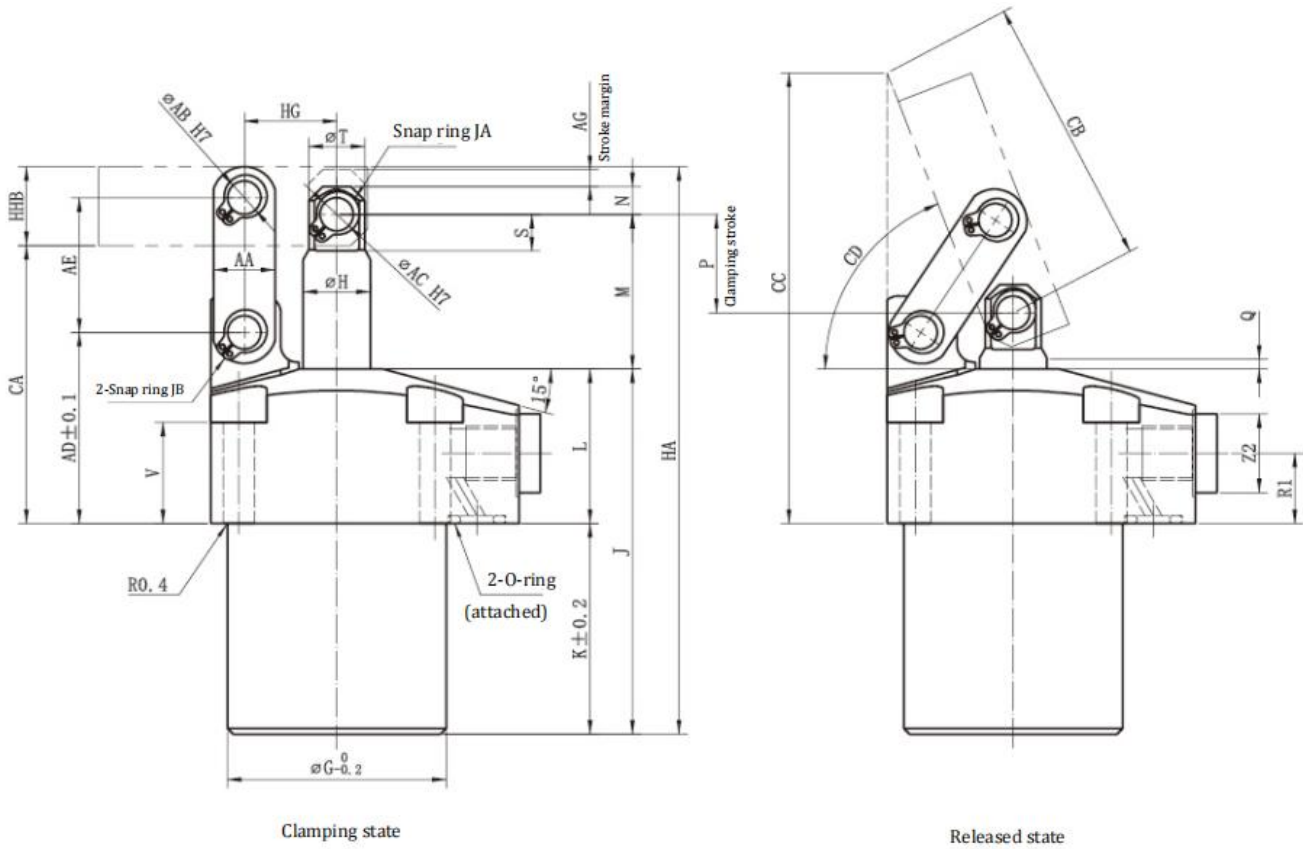

Installation Hole Processing Drawing

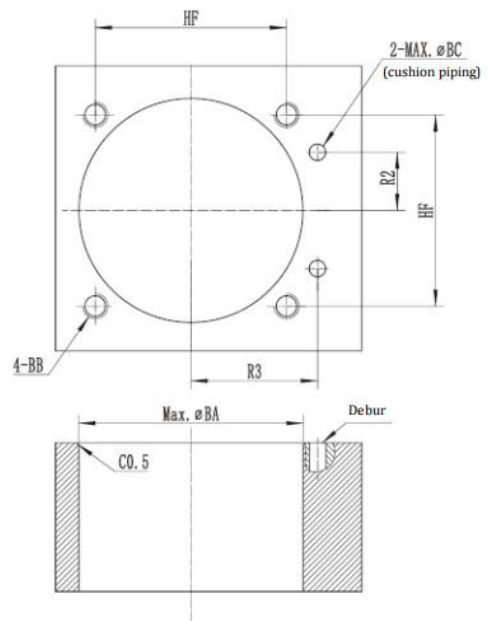

Overall Dimension

Model	HCLT02-L _R	HCLT04-L _R	HCLT06-L _R	HCLT10-L _R	HCLT16-L _R	HCLT25-L _R
HA	101.1	114.1	132.6	147.1	180.1	214.1
HB	45	50	57	70	86	108
HC	55	60	66	82	96	120
HD	32.5	35	37.5	47	53	66
HE	22.5	25	28.5	35	43	54
HF	35.1	40.1	46.1	56.1	68.1	88.1
G	39	47	53	63	78	100
H	12 f7	14 f7	14 f7	16 f7	22.4 f7	28 f7
J	64	72	84	90	109	127
K	37.5	45.5	55.5	54	69	80
L	26.5	26.5	28.5	36	40	47
M	28.5	32	34.5	40	49	61.5
N	5	6	6	8	11	13
P	17.5	20.5	23	26.5	33	42
Q	2	2	2	2	2.5	2.5
R1	12.5	12.5	12.5	14	14	21
R2	11	12	14	18	22.5	25
R3	25	28	30.5	36	42	57
R4	20	22	26	30	38	50
S	6.5	7	7	9	10.8	14.5
T	10	12	12	14	20	26
U ※1	6	6	8	10	11	16
V	18	17	17	20	20	20
W	5.5	5.5	6.8	9	11	14
X	10	10	12	15	18.5	20
Y	Rp1/8	Rp1/8	Rp1/8	Rp1/4	Rp1/4	Rp3/8
Z	3.8	3.8	3.8	4.8	4.8	4.8
Z1	C1.5	C2.5	C2.5	C3	C3.5	C5.5
Z2	14	14	14	19	19	22
O-ring	6.8×1.9	6.8×1.9	6.8×1.9	7.8×1.9	7.8×1.9	9.8×1.9
AA	11	13	15	19	25	32
AB	6 ^{+0.012} ₀	6 ^{+0.012} ₀	8 ^{+0.018} ₀	10 ^{+0.018} ₀	14 ^{+0.018} ₀	16 ^{+0.018} ₀
AC	6 ^{+0.012} ₀	6 ^{+0.012} ₀	6 ^{+0.012} ₀	8 ^{+0.018} ₀	12 ^{+0.018} ₀	14 ^{+0.018} ₀
AD	34	36	39	48	54.5	65
AE	24	26	30	35.5	44	53
AF	21	21	28	37	46	56
AG	3	3	3	3	3	3
BA	40	48	54	64	79	101
BB	M5	M5	M6	M8	M10	M12
BC	4	4	4	6	6	8
CA	49.5	52.5	57	68	80	96
CB	48	59.6	67.3	78.7	98.2	133.5
CC	80.2	92.5	101.3	120.4	144.7	189.2
CD	About 69°	About 71°	About 70°	About 70°	About 69°	About 72°
HHA	12	12	16	19	22	32
HHB	14	16	20	25	31	38
HG	16.5	18.5	21	24.5	30.5	37.5
JA	STW-6	STW-6	STW-6	STW-8	STW-12	STW-14
JB	STW-6	STW-6	STW-8	STW-10	STW-14	STW-16

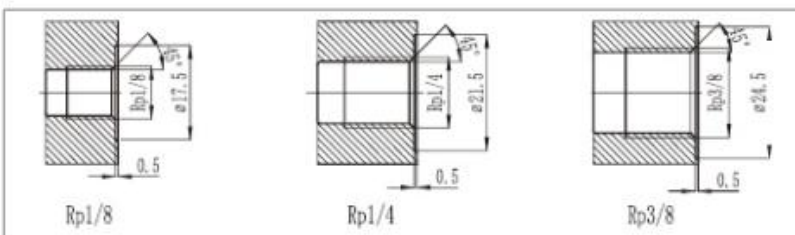

※1: It indicates the width of the opposite side of the front end of the piston rod.